safeCAP SC30

Operating Instructions



Table of Contents

1	Foreword.....	4
2	Safety.....	4
2.1	Notes and symbols used.....	4
2.2	General safety.....	5
2.3	Personnel qualifications.....	5
2.4	Intended use.....	5
2.5	Reasonably foreseeable misuse.....	5
2.6	Determining the lifetime and validating the entire system.....	6
2.7	Example calculation.....	6
3	General description.....	7
3.1	safeCAP SC30.....	7
4	Storage.....	7
5	Assembly.....	7
5.1	Install safeCAP SC30.....	8
5.2	Install protector SCP-6 (optional).....	8
5.3	Install safety relay 3SK1 (optional).....	8
5.4	Connect safeCAP SC30 to safety relay 3SK1.....	9
5.5	Install safety relay MCR 225 (optional).....	10
5.6	Connect safeCAP SC30 to safety relay MCR 225.....	10
5.7	Install safety relay PNOZ s6 (optional).....	10
5.8	Connect safeCAP SC30 to safety relay PNOZ s6.....	11
5.9	Connect safeCAP SC30 to an equivalent T-network.....	11
5.10	Testing the safety function of the SC30.....	12
6	Operation.....	13
6.1	Operating safeCAP SC30.....	13
6.2	Operating safety relay SCR3-3SK1.....	13
7	Maintenance.....	13
7.1	Maintenance operations.....	13
7.2	Testing the safety function of the SC30.....	13
7.3	Troubleshooting.....	13
8	Disassembly.....	14

9	Disposal.....	14
10	Technical specifications.....	14
10.1	Terminal assignment SC30.....	14
10.2	Technical specifications SC30 one-channel.....	14
10.3	Technical specifications SC30 two-channel.....	15
10.4	Technical specifications, safety relay 3SK1.....	16
10.5	Technical specifications, safety relay.....	17
10.6	Technical specifications, safety relay PNOZ s6.....	18
11	Dimensional drawing SC30.....	19
12	Manual updates.....	19
13	Imprint.....	20

1 Foreword

These operating instructions are intended for installers and operators and should be kept for future reference. Read these operating instructions carefully and make sure that you have fully understood the contents before installing or working with the safeCAP SC30. The operator is responsible for validating the entire safety system.

2 Safety

2.1 Notes and symbols used

Warning notes in relation to personal injury / material damage are formulated according to the "SAFE" principle. This means they contain information on the type and source of the hazard, potential consequences as well as how to avoid and avert danger. The following hazard classifications apply in the safety notes:

DANGER

Danger designates a hazardous situation, which, if ignored, will lead to death or serious injury. The symbol next to the warning indicates the type and source of the danger.

WARNING

Warning designates a hazardous situation, which, if ignored, may lead to death or serious injury. The symbol next to the warning indicates the type and source of the danger.

CAUTION

Caution designates a hazardous situation, which, if ignored, may lead to injury. The symbol next to the warning indicates the type and source of the danger.

NOTICE

Notice designates a situation, which may cause material damages and impair the product's function if attention is not paid.

TIP

Tip provides additional useful information about the handling of the product.

Symbol	Meaning
▸	Avoiding and averting danger in the warning note
▶	Instructions for action All instructions to be followed within a procedure are always listed in chronological order.
▪	List

2.2 General safety

All work on electrical systems or operating equipment may only be carried out by a specially qualified electrician according to the applicable electrotechnical regulations.

The safety of the system in which the SENSORswitch is integrated is the responsibility of the operator.

WARNING

Dangerous machine movement

The functioning two-hand control only protects operators from dangerous machine movements.

- Protect the machine danger zone against unauthorized access with additional safety devices.

2.3 Personnel qualifications

A qualified electrician is a person with suitable technical training, expertise and experience as well as knowledge of relevant standards, who can evaluate the work assigned to them correspondingly and recognize potential risks.

The following general safety notes for working with electrical energy must be observed:

WARNING

Improper work on electrical systems!

Electric shock can result in death or life-threatening injuries.

- Before working on electrical systems, disconnect them from their voltage supply and secure them against being switched on again.
- Wear appropriate personal protective equipment (PPE).
- Defects that are ascertained, such as damaged or loose cables, must be remedied immediately.

2.4 Intended use

Combined with the safety relay, safeCAP SC30 ensures safety-related release and interruption of a safety circuit. safeCAP SC30 is used to protect people from work machines with dangerous closing movements. safeCAP SC30 is tested with the following safety relays: MCR 225, 3SK1, 3RK3 and PNOZ s6. Connection of MCR 225, 3SK1 and PNOZ s6 is described as an example in the instructions. The operator is responsible for safety-related release and interruption of the safety circuit.

WARNING

safeCAP SC30 is not suitable for machine processes that require the release and interruption of a safety circuit for a duration longer than 2 minutes.

2.5 Reasonably foreseeable misuse

Any use other than as specified [Chapter , "Intended use"](#) or extending beyond this is deemed to be improper.

The switch is not suitable for:

- use as a two-hand control without the aforementioned relay or in case of use of an equivalent t-network without the independent calculation of the performance level in accordance with ISO 13849-1:2015.
- the release of machine processes for a duration of longer than 2 minutes.
- use as a two-hand control without validation of the entire system.
- use with cables between SC30 and safety relay with a length exceeding 30 m (98 ft).
- use as a two-hand control in combination with another switch.
- use as an emergency stop command device.
- use in potentially explosive atmospheres.
- use outdoors.

2.6 Determining the lifetime and validating the entire system

The following steps are mandatory.

- Determine the real parameters of the system.
 - Required performance level
 - d_{op}
 - h_{op}
 - t_{cycle}
- The operator must verify that the lifetime T_M is not exceeded.
- Validate the entire system.
- Observe the safety considerations in the operating instructions of the safety relay.

2.7 Example calculation

The following values are only examples and must be replaced with your own values.

- Performance level e must be achieved.

- $d_{op} = 250 \text{ d}$

- $h_{op} = 24 \text{ h}$

- $t_{cycle} = 10 \text{ s}$

n_{op} [cycles / year]

$$n_{op} = (d_{op} * h_{op} * 3600 \text{ s}) / t_{cycle}$$

$$n_{op} = 250 \text{ d} / \text{y} * 24 \text{ h} / \text{d} * 3600 \text{ s} / \text{h} / 10 \text{ s} / \text{cycle} = 2,160,000 \text{ cycles} / \text{year}$$

According to the operating instructions, the relay has a lifetime of approximately 20 million cycles before a dangerous failure can occur.

$$T_M = 20,000,000 / n_{op}$$

$$T_M = 20,000,000 / 2,160,000 = 9.3 \text{ years}$$

According to this calculation, the relay has to be replaced after 9.3 years.

For other relays, values such as B_{10D} or T_{10D} can be specified. These values are not considered here and can be requested from CAPTRON.

3 General description

3.1 safeCAP SC30

safeCAP SC30 is equipped with two LEDs. The green LED (1) lights up when it is ready for operation. The yellow LED (2) lights up when actuated.



4 Storage

	Conditions
safeCAP SC30	-30°C (-22°F) to 80°C (176°F)
Safety relay SCR3-3SK1	-40°C (-40°F) to 80°C (176°F)
Protector SCP-6	Protected against UV light for max. two years 20°C (68°F) 50% -70% relative air humidity

5 Assembly

⚠ WARNING



Improper work on electrical systems!

Electric shock can result in death or life-threatening injuries.

- ▶ Before working on electrical systems, disconnect them from their voltage supply and secure them against being switched on again.
- ▶ Work on electrical installations should be carried out only by qualified personnel in compliance with local and national electrical regulations and specifications.

⚠ WARNING

Improper safeCAP SC30 assembly!

An improperly assembled or non-functional two-hand control device can result in death or life-threatening injuries.

- ▶ Select mounting surfaces for the safeCAP SC30 based on the dimensions and spacing specified in DIN EN ISO 1385:2019.
- ▶ Protect safeCAP SC30 against unintended actuation, for example SCP-6.
- ▶ Before working on the machine, check safeCAP SC30 for proper function.

The safety distance between the machine and the two-hand control is calculated based on the following formula.

$$S = K (t_1 + t_2) + C$$

- **(S)** Safety distance
- **(K)** Expected approach velocity of the human body or body parts. In accordance with EN ISO 13855:2010
 - Walking speed 1600 mm/s
 - Grasping speed 2000 mm/s
- **(t₁)** Time the safety equipment needs to respond.
- **(t₂)** Time the machine needs after receiving the safety equipment signal until the machine stops.
- **(C)** Additional horizontal distance from the danger zone in mm in accordance with EN ISO 13855:2010

5.1 Install safeCAP SC30

- ▶ Disconnect the system from its voltage supply and secure it against being switched on again.
- ▶ Clean the area below the switch.
- ▶ Unscrew the lock nuts (1) on the switch.
- ▶ Insert the switch into the prepared Ø 22.5 mm hole and screw the lock nuts back on.
- ▶ Align safeCAP SC30 and tighten the lock nuts.

Wiring outside of enclosed installation spaces must be protected against mechanical damage (including vibration or bending, for example).



5.2 Install protector SCP-6 (optional)

- ▶ Clean the area above the switch. The bonding surface must be free of dust, grease, oil, silicone and separating agents.
- ▶ Remove the film on the adhesive strip from the back of the protector and position it above safeCAP SC30.
- ▶ Press down firmly on the entire surface of the protector.



5.3 Install safety relay 3SK1 (optional)

TIP

More detailed information can be found in the supplier documentation.

5.4 Connect safeCAP SC30 to safety relay 3SK1

The lines between safeCAP SC30 and the safety relay must be laid separately of other signal paths or live lines.

- ▶ Disconnect the system from its voltage supply.
- ▶ Set the DIP switch (2). The position of the DIP switch is indicated in the circuit diagram.
- ▶ Connect safeCAP SC30 to the safety relay using a 4-pin M 12 cable according to the circuit diagram. The optional cables LKW 40-5 (5 m) / LKW 40-10 (10 m) or LKG 40-5 (5 m) / LKG-40-10 (10 m) can be used.

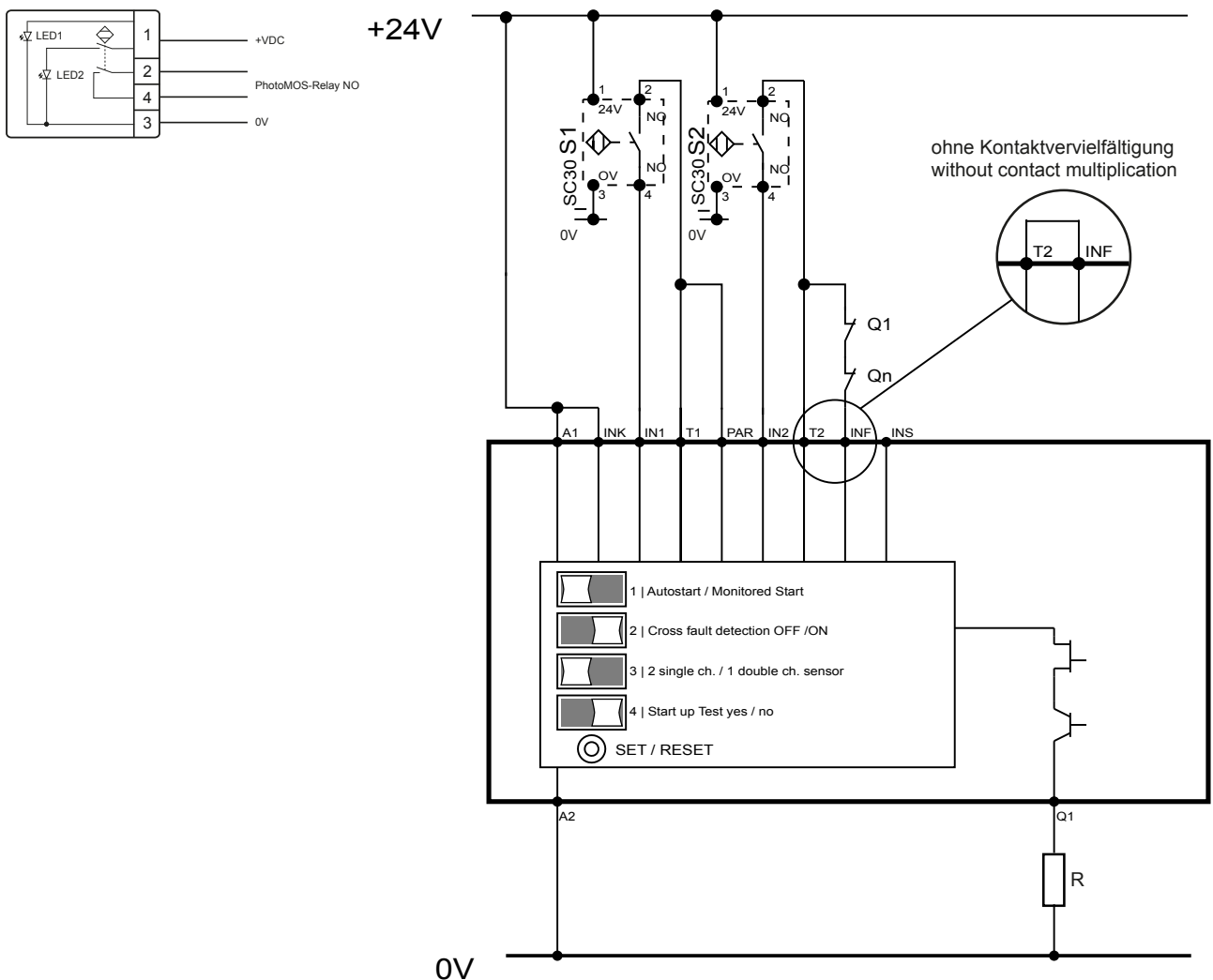
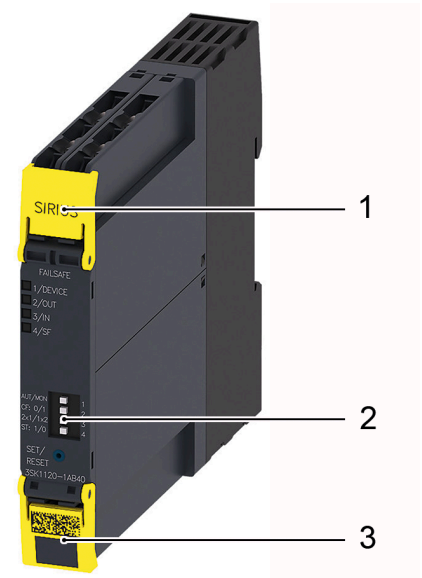

5.5 Install safety relay MCR 225 (optional)

TIP

More detailed information can be found in the supplier documentation.

5.6 Connect safeCAP SC30 to safety relay MCR 225

- ▶ Disconnect the system from its voltage supply.
- ▶ Connect safeCAP SC30 to the safety relay using a 6-pin M 12 cable according to the circuit diagram. The optional cables LKW 60-5 (5 m) / LKW 60-10 (10 m) or LKG 60-5 (5 m) / LKG-60-10 (10 m) can be used.

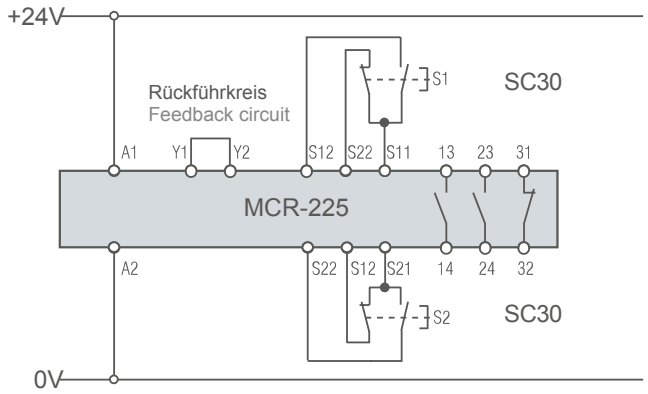
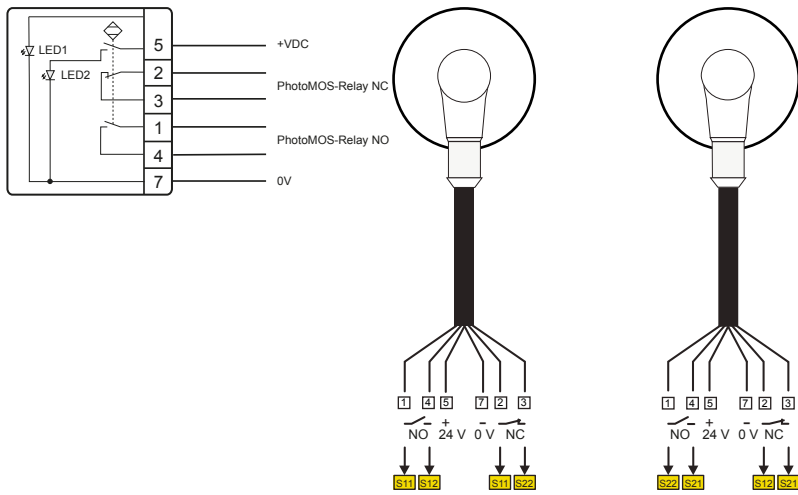

5.7 Install safety relay PNOZ s6 (optional)

TIP

More detailed information can be found in the supplier documentation.

5.8 Connect safeCAP SC30 to safety relay PNOZ s6

- ▶ Disconnect the system from its voltage supply.
- ▶ Connect safeCAP SC30 to the safety relay using a 6-pin M 12 cable according to the circuit diagram. The optional cables LKW 60-5 (5 m) / LKW 60-10 (10 m) or LKG 60-5 (5 m) / LKG-60-10 (10 m) can be used.

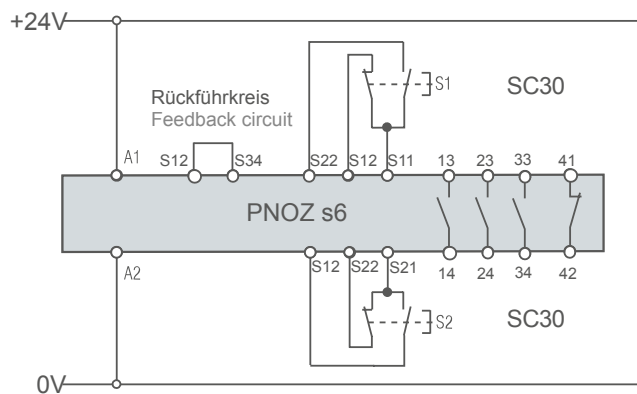
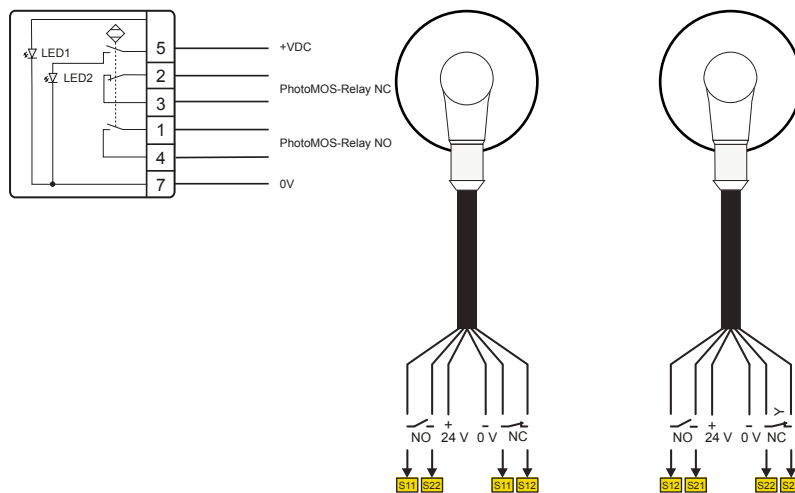

5.9 Connect safeCAP SC30 to an equivalent T-network

The equivalent T-network realizes parts of the start/restart safety function in accordance with ISO 13849-1:2015 Table 8.

If an equivalent T-network is used for the relay, the following conditions must be met.

- The entire FIT value for the equivalent T-network must be determined via an FMEDA or an equivalent method.
- The equivalent T-network must be certified in accordance with EN 60947-5-1:2017.
- Must not exceed a FIT value of 40.
- Performance level e category 4 in accordance with ISO 13849-1:2015 must be met.
- $MTTF_d$ must exceed 45.

- The equivalent T-network must have a diagnosis with a diagnostic coverage of at least 99%.
- The following formula must be met:

$$MTTF_d (\text{Equivalent t-network}) = MTTF_d (\text{safeCAP}) * 30 / (MTTF_d (\text{safeCAP}) - 30).$$

Exception: $MTTF_d (\text{safeCAP}) = 100$;

This data is indicated to achieve performance level e. All other requirements for two-hand controls must be met in accordance with the standard ISO 13851:2019.

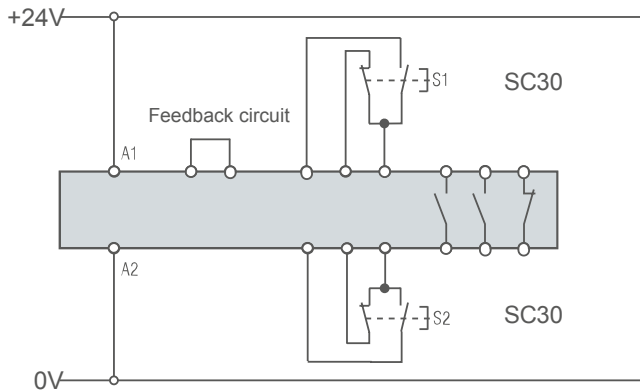

The safety function depicted corresponds to the start/restart function in accordance with Chapter 5.4.3 of ISO 13849-1 [1] (see also ISO 13849-1 Table 8).

5.10 Testing the safety function of the SC30

To ensure the safety function of the SC30, test the safety function as follows.

- During initial start-up
- Once the testing interval has expired
- After maintenance and repairs

Record the results.

- ▶ Disconnect safeCAP SC30 from the machine.
- ▶ Connect a meter to the contacts of the safety relay that release the machine function.
- ▶ Actuate the SC30s one after another.
 - ✓ The LEDs must light up in green and yellow.
 - ✓ The safety relay must not release N/O or N/C contacts.
- Switching on must be verified at the output contacts of the safety relay using the meter and must not exceed the safety times (0.5 s in this case).
- ▶ Disconnect the safeCAP SC30 from the power supply.
- ▶ Actuate and continue actuating the SC30.
- ▶ Restore the power supply.
 - ✓ The LEDs must light up in green and yellow.
 - ✓ The safety relay must not release N/O or N/C contacts.

6 Operation

6.1 Operating safeCAP SC30

- ▶ Touch both safeCAP SC30 switches simultaneously (within 0.5 s).
- ▶ The machine process is triggered.

6.2 Operating safety relay SCR3-3SK1

TIP

More detailed information can be found in the supplier documentation.

7 Maintenance

7.1 Maintenance operations

Carry out the following maintenance operations at the specified intervals.

Maintenance operation	as needed	annually	Testing interval
Clean the switch surface	X		
Test the safety function			X
Check cables for intactness and firm fit		X	
Check screw connections for tightness		X	

7.2 Testing the safety function of the SC30

How to test the safety of SC30 see ["Testing the safety function of the SC30"](#), page 12.

7.3 Troubleshooting

Green LED (1) isn't lighting up.

- ▶ Check the plug on the back for tightness and damage.
- ▶ Check cable for damage.
- ▶ Check the power supply.

Yellow LED (2) doesn't light up when actuated.

- ▶ Switch actuated too slowly.
- ▶ Switch actuated too fast.
- ▶ Switch actuated with excessively thick gloves.
- ▶ Switch surface excessively dirty.



Green LED (1) and yellow LED (2) are lit up. Process on the machine not triggered.

- Have the switch checked for proper connection.

8 Disassembly

⚠ WARNING

Improper work on electrical systems!

Electric shock can result in death or life-threatening injuries.

- Before working on electrical systems, disconnect them from their voltage supply and secure them against being switched on again.
- Work on electrical installations should be carried out only by qualified personnel in compliance with local and national electrical regulations and specifications.

- Disconnect the system from its voltage supply and secure it against being switched on again.
- Disconnect the electrical connection between safeCAP SC3 and the safety relay.
- Loosen the nuts (1) and pull out safeCAP SC3.



9 Disposal

Different types of electrical and electronic components must be recycled according to their type. All applicable statutory, state and local laws and regulations must be complied with.

10 Technical specifications

10.1 Terminal assignment SC30

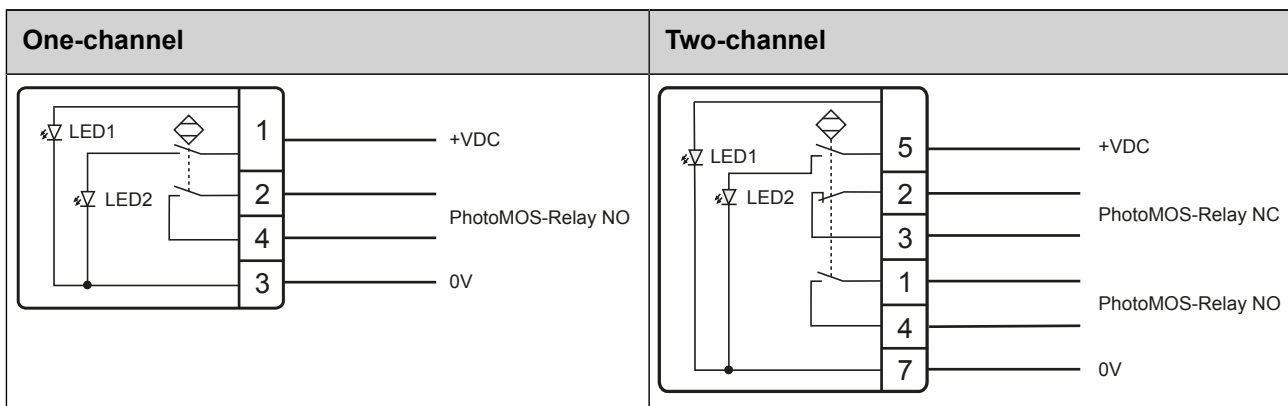

10.2 Technical specifications SC30 one-channel

Operating voltage	— 24 V (19.2 to 28.8 V)
-------------------	-------------------------

Contact rating	100 mA (70 mA at 75°C)
Output	PhotoMOS relay NO
Output pulse	Constant signal when actuated
LED 1	Green LED
LED 2	Yellow LED
Reverse polarity protection	Yes
Short circuit protection	Yes
Power consumption	Max. 20 mA at 24 V
Operating temperature	-25°C (-13°F) to +75°C (167°F)
Degree of protection IP	Front IP69K plug IP67
Type of actuation	Capacitive
Actuation force	No actuation force required
Rated insulation voltage	32 V
Switch-off delay T_a	Max. 50 ms
Power-up delay	Max. 30 ms
MTTF _d	100 years

10.3 Technical specifications SC30 two-channel

Operating voltage	— 24 V (19.2 to 28.8 V)
Contact rating	100 mA (70 mA at 75°C)
Output	PhotoMOS relay NC, NO
Output pulse	Constant signal when actuated
LED 1	Green LED
LED 2	Yellow LED
Reverse polarity protection	Yes
Short circuit protection	No
Power consumption	Max. 20 mA at 24 V
Operating temperature	-25°C (-13°F) to +75°C (167°F)
Degree of protection IP	Front IP69K plug IP67

Type of actuation	Capacitive
Actuation force	No actuation force required
Rated insulation voltage	32 V
Switch-off delay T_a	Max. 50 ms
Power-up delay	Max. 30 ms
MTTF _d	100 years

10.4 Technical specifications, safety relay 3SK1

General data	
Wire cross-section	0.5 - 2.5 mm ²
Operating temperature	- 25 to + 60°C
Storage temperature	- 40 to + 80°C
Switching capacity, relay outputs Normally open contacts Normally closed contacts	5 A / 24 V DC (DC 13) 1 A / 24 V DC (DC 13)
Resistance to short circuit Max. safety fuse Circuit breaker	6 A gL C 1 A

Safety figures	Value	Unit
Category	4	
PL	e	
MTTF _d	100	[years]
DC _{avg}	99.0	[%]
PFH _d	1.3 e-9	[1/h]
average usage d _{op}	220	[days/year]
average usage h _{op}	12	[hours/day]
t _{cycle}	20	[s/cycle]
Lifetime	20	[years]
Test Time Interval	2	[years]

TIP

Refer to the safety relay instructions for more technical specifications.

10.5 Technical specifications, safety relay

General data	
Wire cross-section	0.2 - 2.5 mm ²
Operating temperature	- 25 to + 55°C
Storage temperature	- 25 to + 85 °C
Switching capacity	NO 3 A / 230 V AC (AC 15) NC 1 A / 230 V AC (AC15) NO 1 A / 24 V DC (DC 13) NC 1 A / 24 V DC (DC 13)
Resistance to short circuit Max. safety fuse Circuit breaker	6 A gL C 8 A

Safety figures	Value	Unit
Category	4	
PL	e	
MTTF _d	90	a, years
DC _{avg}	99.0	[%]
PFH _d	7.51e-09	[1/h]
average usage d _{op}	220	[days/year]
average usage h _{op}	12	[hours/day]
t _{cycle}	95	[s/cycle]
Lifetime	20	years
Test Time Interval	1	months

TIP

Refer to the safety relay instructions for more technical specifications.

10.6 Technical specifications, safety relay PNOZ s6

General data	Value
Wire cross-section	0.2 - 2.5 mm ²
Operating temperature	- 10 to + 55°C
Storage temperature	- 40 to + 85°C
Switching capacity	max. 6 A / 240 V AC (AC1) max. 5 A / 230 V AC (AC15) max. 6 A / 24 V DC (DC1) max. 5 A / 24 V AC (DC13)
External contact fuse Fast-acting safety fuse Slow-blow safety fuse Circuit breaker	10 A 6 A 6 A, 24V AC/DC, characteristic B/C

Safety figures	Value	Unit
Category	4	
PL	e	
MTTF _d	100	a, years
DC _{avg}	99.0	[%]
PFH _d	2.62e-09	[1/h]
average usage d _{op}	220	[days/year]
average usage h _{op}	12	[hours/day]
t _{cycle}	20	[s/cycle]
Lifetime	20	years
Test Time Interval	2	years

TIP

Refer to the safety relay instructions for more technical specifications.

11 Dimensional drawing SC30

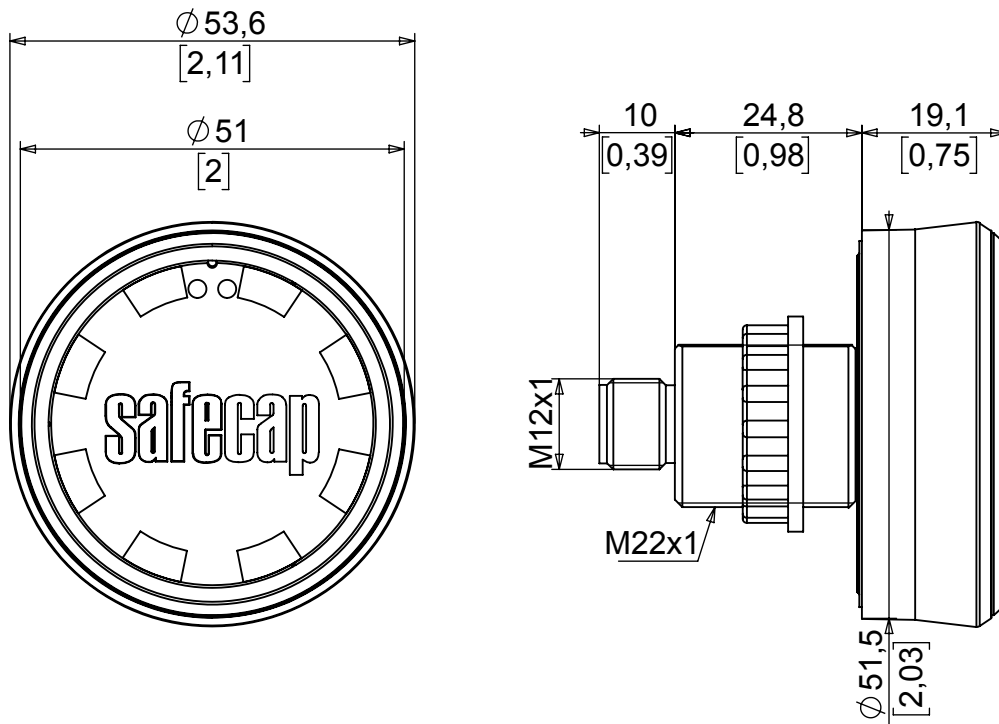

12 Manual updates

CAPTRON reserves the right to make changes to the contents of this manual as needed. The most current version can be found on our website www.captron.com.

13 Imprint

The operating instructions have been authored and published by

CAPTRON Electronic GmbH

Johann-G.-Gutenberg-Straße 7

82140 Olching – Germany

Tel.: +49 (0) 8142 44 88 – 160

sales@captron.com

www.captron.com

Copyright 2024



safeCAP SC30 Draft